



ETA-Danmark A/S
Göteborg Plads 1
DK-2150 Nordhavn
Tel. +45 72 24 59 00
Internet www.etadanmark.dk

Authorized and notified according
to Article 29 of the Regulation (EU)
No 305/2011 of the European
Parliament and of the Council of 9
March 2011

MEMBER OF EOTA



European Technical Assessment ETA-22/0793 of 2024/04/08

General Part

Technical Assessment Body issuing the ETA and designated according to Article 29 of the Regulation (EU) No 305/2011: ETA-Danmark A/S

Trade name of the
construction product:

Self-drilling/self-tapping fasteners: SX3, SX5, TDA-S,
SDA4, SX4, SX4-SH, SCFW, SDA5, SDAW

Product family to which the
above construction product
belongs:

Fastening screws for metal members and sheeting

Manufacturer:

SFS Group Schweiz AG
Rosenbergsaustrasse 10
CH-9435 Heerbrugg
Telephone: +41 71 727 51 51
www.sfs.com

Manufacturing plant:

SFS Production Plants

This European Technical
Assessment contains:

21 pages including 16 annexes which form an integral
part of the document

This European Technical
Assessment is issued in
accordance with Regulation
(EU) No 305/2011, on the
basis of:

EAD 330046-01-0602 – Fastening screws for metal
members and sheeting

This version replaces:

The ETA with the same number issued on 2023-01-06

Translations of this European Technical Assessment in other languages shall fully correspond to the original issued document and should be identified as such.

Communication of this European Technical Assessment, including transmission by electronic means, shall be in full (excepted the confidential Annex(es) referred to above). However, partial reproduction may be made, with the written consent of the issuing Technical Assessment Body. Any partial reproduction has to be identified as such.

II SPECIFIC PART OF THE EUROPEAN TECHNICAL ASSESSMENT

1 Technical description of product

The SFS self-drilling/self-tapping fasteners: SX3, SX5, TDA-S, SDA4, SX4, SX4-SH, SCFW, SDA5, SDAW for metal cladding panels, are self-drilling screws as listed in Table 1. The fasteners are made of carbon steel, austenitic stainless steel or a bimetal combination with drill bits made of galvanized/painted carbon steel. Some of the fasteners are completed with a metallic/EPDM sealing washer.

The fastening screws for metal members and sheeting and the corresponding connections are subject to tension and/or shear forces. Samples of fastenings screws for metal members and sheeting are shown in Figure 1.

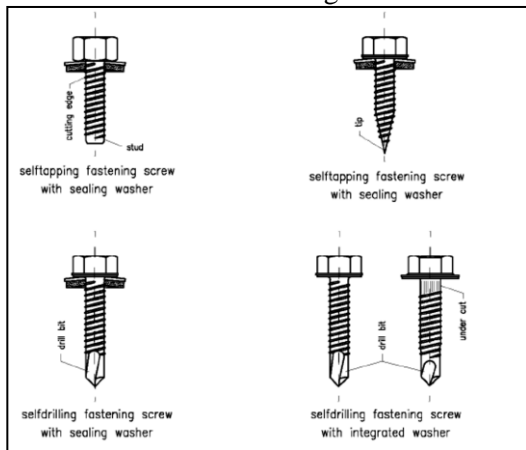

Figure 1: Fastening screws for metal members and sheeting

The components identified in Table 1 have the geometrical characteristics defined in the Annexes and are factory produced by different manufacturing plants.

screw	washer	Material of components		Annex
		comp I	comp II	
SDA5-5,5xL	none	aluminum	aluminum	3
		steel	aluminum	4
SX3 4,8xL	none	-	aluminum	5
		steel	steel	6
SX3-5,5xL,	optional	-	steel or aluminum	7
TDA-S-5,8xL	none	-	steel or aluminum	8
SX5-6,3xL	optional	-	steel	9
SCFW-S-5xL	optional	-	timber	10
SDA4-5,8xL	none	-	aluminum	11
SX4-5,8xL	none	-	steel or aluminum	12-13
SX4-SH-5,8xL	none	-	steel or aluminum	14-15
SDAW-4,5xL	none		timber or aluminum	16

Table 1: Fastening screws included in this ETA.

2 Specification of the intended use(s) in accordance with the applicable European Assessment Document (hereinafter EAD)

The SFS Self-drilling/self-tapping fastening screws are intended to be used for fastening metal members and sheeting to metal or timber supporting structures.

The sheeting can either be used as wall or roof cladding or as load bearing wall and roof element. The fastening screws can also be used for the fastening of any other thin gauge metal members.

The intended use comprises fastening screws for metal members and sheeting and connections for indoor and outdoor applications. Fastening screws which are intended to be used in external environments with $\geq C2$ corrosion according to the standard EN ISO 12944-2 are made of stainless steel. Furthermore the intended use comprises connections with predominantly static loads (e.g. wind loads, dead loads).

The fastening screws for metal members and sheeting are not intended for re-use.

The field of application of the screws is shown in Table 1. The corresponding sheet thicknesses are shown in the annexes.

The installation should be carried out according to the ETA holder's specifications, using the specific kit components, manufactured by suppliers of the ETA holder and carried out by appropriately qualified staff with supervision of the technical responsible of the site.

The verification and assessment methods on which this European Technical Assessment is based lead to the assumption of a working life of at least 25 years, that the conditions lay down for the installation, packaging, transport and storage as well as appropriate use, maintenance and repair are met.

The indications given on the working life cannot be interpreted as a guarantee given by the manufacturer but are to be regarded only as a means for choosing the right product in relation to the expected economically reasonable working life of the works.

3 Performance of the product and references to the methods used for its assessment.

Characteristic	Assessment of characteristic
3.1 Mechanical resistance and stability (BWR 1)	
Shear resistance of the connection	See information in annex 3-16
Tension resistance of the connection	See information in annex 3-16
Design resistance in case of combined tension and shear forces (interaction)	Calculated according to equation in annex 2 with the combined tension and shear forces from annex 3-16.
Check of deformation capacity in case of constraining forces due to temperature	No performance assessed
Durability	Not relevant. The fastening screws are made of stainless steel intended to be used in external environments with \geq C2 corrosion. EPDM Washer: No performance assessed
3.2 Safety in case of fire (BWR 2)	
Reaction to fire	The SFS fastening screws are classified as Euroclass A1 in accordance with EN 13501-1 and Commission Delegated Regulation 2016/364 on the basis of EC Decision 96/603/EC (as amended) without the need for further testing.

3.8 Methods of verification

The product is fully covered by EAD 330046-01-0602.

3.9 General aspects related to the fitness for use of the product.

The European Technical Assessment is issued for the product based on agreed data/information, deposited with ETA-Danmark, which identifies the product that has been assessed and judged. Changes to the product or production process, which could result in this deposited data/information being incorrect, should be notified to ETA-Danmark before the changes are introduced. ETA-

Danmark will decide if such changes affect the ETA and consequently the validity of the CE marking based on the ETA and if so whether further assessment or alterations to the ETA, shall be necessary.

The SFS Self-drilling/self-tapping fasteners: SX3, SX5, TDA-S, SDA4, SX4, SX4-SH, SCFW, SDA5, SDAW for metal cladding panels are manufactured in accordance with the provisions of this European Technical Assessment using the manufacturing processes as identified in the inspection of the plant by the notified inspection body and laid down in the technical documentation.

4 Assessment and verification of constancy of performance (hereinafter AVCP) system applied, with reference to its legal base.

4.1 AVCP system

According to the decision 1998/214/ECEC of the European Commission, as amended by 2001/596/EC, the system(s) of assessment and verification of constancy of performance (see Annex III to Regulation (EU) No 305/2011) is 2+.

5 Technical details necessary for the implementation of the AVCP system, as provided for in the applicable EAD.

Technical details necessary for the implementation of the AVCP system are laid down in the control plan deposited at ETA-Danmark prior to CE marking.

Issued in Copenhagen on by

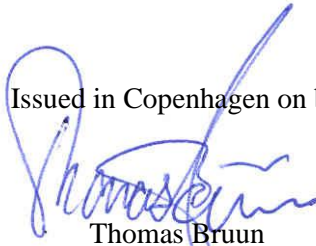

Thomas Bruun
Managing Director, ETA-Danmark

Exemplary execution of a connection

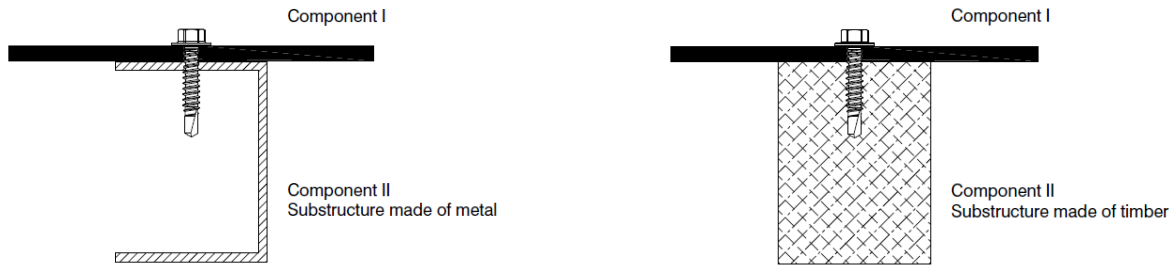

Dimensions

Design relevant dimensions are indicated as follows:

- t_I Thickness of component I
- t_{II} Thickness of component II made of metal
- l_{ef} Effective screw-in length in component II made of timber (without drill point)

The thickness t_I corresponds to the load-bearing screw-in length of the fastening screw in component II, if the load-bearing screw-in length does not cover the entire component thickness.

Resistance values

The resistance values of a connection are indicated as follows:

- $N_{R,k}$ Characteristic tension resistance
- $V_{R,k}$ Characteristic shear resistance

In some cases component-specific resistance values are indicated:

- $N_{R,I,k}$ Characteristic pull-through resistance of component I
- $N_{R,II,k}$ Characteristic pull-out resistance of component II

Additionally indicated values for component II made of timber:

- $M_{y,Rk}$ Characteristic yield moment of the fastening screw
- $f_{ax,k}$ Characteristic withdrawal strength of timber

Terms and explanations

Fastening screws for metal members and sheeting

Annex 1

Design values

The design values of a connection have to be determined as follows:

$$N_{R,d} = \frac{N_{R,k}}{\gamma_M} \qquad V_{R,d} = \frac{V_{R,k}}{\gamma_M}$$

- $N_{R,d}$ Design value of tension resistance
- $V_{R,d}$ Design value of shear resistance
- γ_M Partial safety factor

The recommended partial safety factor γ_M is 1.33, provided no partial safety factor is given in national regulations or national Annexes to Eurocode 3.

Special conditions

If the thickness of component I (t_I) or component II (t_{II}) is between two indicated thicknesses, the resistance values $N_{R,k}$ and $V_{R,k}$ can be determined by linear interpolation. The same applies to screw-in lengths l_{ef} and l_p .

If component II made of metal with thickness $t_{II} < 5$ mm leads to an asymmetric loading of the connection (e.g. Z-profile), the resistance values $N_{R,k}$ have to be reduced to 70%.

In case of combined loading of a connection by tension and shear forces the following interaction equation has to be taken into account:

$$\frac{N_{S,d}}{N_{R,d}} + \frac{V_{S,d}}{V_{R,d}} \leq 1.0$$

- $N_{S,d}$ Design value of the applied tension forces
- $V_{S,d}$ Design value of the applied shear forces

Installation conditions

The installation is carried out according to manufacturer's instruction.

The load-bearing screw-in length of the fastening screw specified by the manufacturer has to be taken into account.

The fastening screws have to be processed with suitable drill driver (e.g. cordless drill driver with depth stop).

The fastening screws have to be fixed rectangular to the surface of the component.

Component I and component II have to be in direct contact to each other. The use of compression resistant thermal insulation strips up to a thickness of 3 mm is allowed.

Design and installation	Annex 2
Fastening screws for metal members and sheeting	

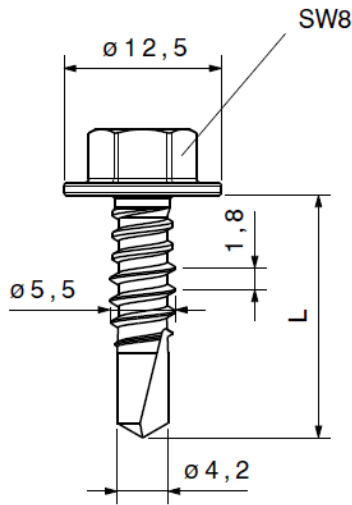

Materials:

Fastener: Stainless steel A2 or A4 - EN ISO 3506

Washer: -

Component I: Aluminum alloy - EN 573

Component II: Aluminum alloy - EN 573

Drilling-capacity: $\Sigma(t_{II}) \leq 4.00$ mm

Component I and II $R_m \geq 165$ N/mm ²	t_{II} [mm]				
	1.50	2.00	2.50	3.00	4.00
$d_{pd,I}$ [mm]	5.2				
$V_{R,k}$ [kN]	2.00	1.51	2.03	2.24	2.44
	2.50	1.51	2.10	2.41	2.86
t_I [mm]	3.00	1.51	2.17	2.57	3.28
	4.00	1.51	2.30	2.89	4.12
$N_{R,II,k}$ [kN]	0.83	1.30	1.88	2.45	4.12

Component I and II $R_m \geq 215$ N/mm ²	t_{II} [mm]				
	1.50	2.00	2.50	3.00	4.00
$d_{pd,I}$ [mm]	5.2				
$V_{R,k}$ [kN]	2.00	1.97	2.64	2.91	3.18
	2.50	1.97	2.73	3.13	3.73
t_I [mm]	3.00	1.97	2.82	3.34	4.28
	4.00	1.97	2.99	3.76	5.37
$N_{R,II,k}$ [kN]	1.09	1.70	2.45	3.19	5.36

Additional definitions

The resistance value $N_{R,k}$ can be determined as follows: $N_{R,k} = \min \{ N_{R,I,k} | N_{R,II,k} \}$. $N_{R,I,k}$ is to be calculate according to EN 1999-1-4:2007, equation (8.13).

Self-drilling screw

SDA5-5,5xL

Annex 3

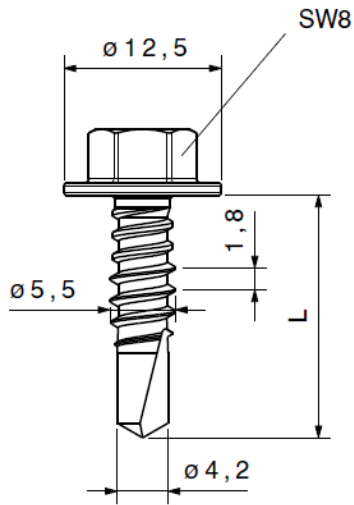

Materials:

Fastener: Stainless steel A2 or A4 - EN ISO 3506

Washer: -

Component I: Stainless steel - EN 10088 - $R_m \geq 550$ N/mm

Component II: Aluminum alloy - EN 573

Drilling-capacity: $\Sigma(t_{II}) \leq 4.00$ mm

Component II $R_m \geq 165$ N/mm ²	t_{II} [mm]				
	1.50	2.00	2.50	3.00	4.00
$d_{pd,I}$ [mm]	5.5				
$V_{R,k}$ [kN]	2.00	-	2.32	2.56	2.80
	3.00	-	2.44	2.78	3.12
t_I [mm]	4.00	1.90	2.56	3.00	3.44
$N_{R,II,k}$ [kN]	0.83	1.30	1.88	2.45	4.12

Component II $R_m \geq 215$ N/mm ²	t_{II} [mm]				
	1.50	2.00	2.50	3.00	4.00
$d_{pd,I}$ [mm]	5.5				
$V_{R,k}$ [kN]	2.00	-	3.03	3.34	3.65
	3.00	-	3.18	3.63	4.07
t_I [mm]	4.00	2.47	3.33	3.91	4.48
$N_{R,II,k}$ [kN]	1.09	1.70	2.45	3.19	5.36

Additional definitions

Self-drilling screw

SDA5-5,5xL

Annex 4

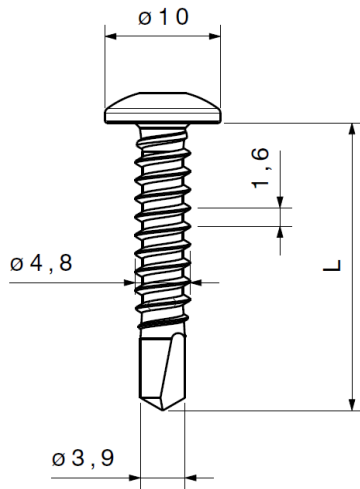

Materials:

Fastener: Stainless steel A2 or A4 - EN ISO 3506

Washer: -

Component I: -

Component II: Aluminum alloy - EN 573

Drilling-capacity: $\Sigma(t_{II}) \leq 3.00$ mm

Component II	Aluminum alloy with $R_m \geq 165$ N/mm ² and $R_{p0,2} \geq 120$ N/mm ²			
	t_{II} [mm]			
	1.80	2.00	2.50	3.00
$N_{R,II,k}$ [kN]	1.21	1.36	1.99	2.59

Component II	Aluminum alloy with $R_m \geq 215$ N/mm ² and $R_{p0,2} \geq 160$ N/mm ²			
	t_{II} [mm]			
	1.80	2.00	2.50	3.00
$N_{R,II,k}$ [kN]	1.58	1.77	2.59	3.37

Additional definitions

Self-drilling screw	Annex 5
SX3-4,8xL	

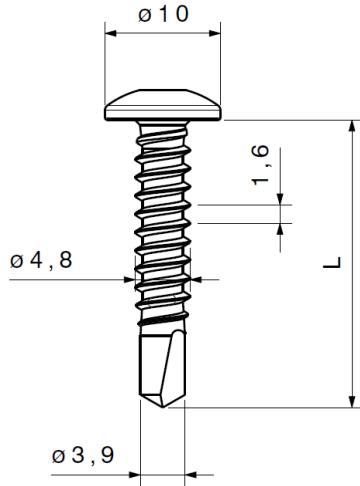

Materials:

Fastener: Stainless steel A2 or A4 - EN ISO 3506

Washer: -

Component I: S235 to S355 - EN 10025
S280GD to S450GD - EN 10346

Component II: S235 to S355 - EN 10025
S280GD to S450GD - EN 10346

Drilling-capacity: $\Sigma(t_{II}) \leq 3.00$ mm

		t_{II} [mm]					
		1.20	1.50	1.75	2.00	2.50	3.00
$d_{pd,I}$ [mm]		5.0					
$V_{R,k}$ [kN]	1.20	3.03	3.03	3.03	3.03	3.03	3.03
	1.50	3.03	4,21	4,21	4,21	4,21	4,21
	1.75	3.03	4,21	4,26	4,26	4,26	4,26
	t_i [mm]	2.00	3.03	4,21	4,26	4,31	4,31
	2.50	3.03	4,21	4,26	4,31	4,31	4,31
	3.00	3.03	4,21	4,26	4,31	4,31	4,31
$N_{R,k}$ [kN]	1.20	0,90	1,32	1,94	2,51	3,08	3,72
	1.50	0,90	1,32	1,94	2,51	3,08	3,72
	1.75	0,90	1,32	1,94	2,51	3,08	3,72
	t_i [mm]	2.00	0,90	1,32	1,94	2,51	3,08
	2.50	0,90	1,32	1,94	2,51	3,08	3,72
	3.00	0,90	1,32	1,94	2,51	3,08	3,72
$N_{R,II,k}$ [kN]		0,90	1,32	1,94	2,51	3,08	3,72

Additional definitions

For component I and component II made of S320GD to S450GD the resistance values may be increased by 8.3%.

Self-drilling screw

SX3-4,8xL

Annex 6

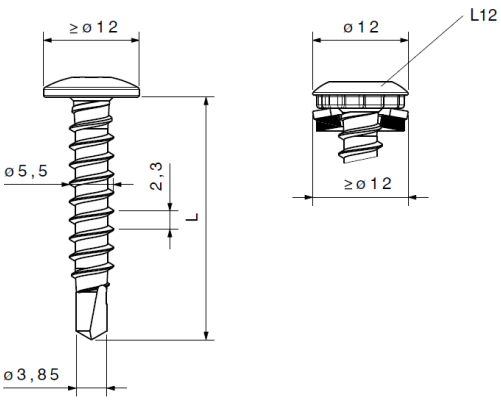
	<p>Materials:</p> <p>Fastener: Stainless steel A2 or A4 - EN ISO 3506</p> <p>Washer: -</p> <p>Component I: -</p> <p>Component II: S235 to S355 - EN 10025 S280GD to S450GD - EN 10346 Aluminum alloy - EN 573</p> <hr/> <p>Drilling-capacity: $\Sigma(t_{II}) \leq 3.00$ mm</p>
---	---

Component II	Aluminum alloy with $R_m \geq 165$ N/mm ² and $R_{p0,2} \geq 120$ N/mm ²			
	t_{II} [mm]			
	1.80	2.00	2.50	3.00
$N_{R,II,k}$ [kN]	1.61	1.81	2.57	3.15

Component II	Aluminum alloy with $R_m \geq 215$ N/mm ² and $R_{p0,2} \geq 160$ N/mm ²			
	t_{II} [mm]			
	1.80	2.00	2.50	3.00
$N_{R,II,k}$ [kN]	2.10	2.35	3.35	4.10

Component II	S235 to S355, S280GD to S450GD			
	t_{II} [mm]			
	1.20	1.50	2.00	3.00
$N_{R,II,k}$ [kN] ¹⁾	1.84	2.46	3.57	6.32

Additional definitions

Index ¹⁾: For component II made of S320GD to S450GD the resistance values may be increased by 8.3%.

Self-drilling screw	Annex 7
SX3-5,5xL	

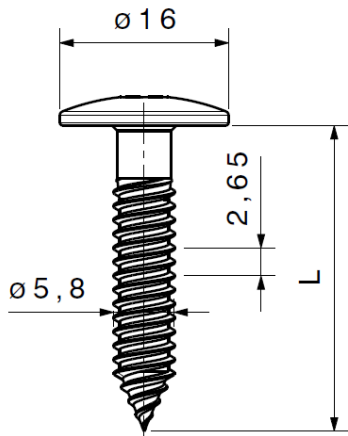

Materials:

Fastener: Stainless steel A2 or A4 - EN ISO 3506

Washer: -

Component I: -

Component II: S235 to S355 - EN 10025
S280GD to S450GD - EN 10346
Aluminum alloy - EN 573

Predrill-diameter: Ø 4.5 mm

Component II	Aluminum alloy with $R_m \geq 165 \text{ N/mm}^2$ and $R_{p0.2} \geq 120 \text{ N/mm}^2$			
	t_{II} [mm]			
	1.80	2.00	2.50	3.00
$N_{R,II,k}$ [kN]	1.57	1.76	2.49	3.33

Component II	Aluminum alloy with $R_m \geq 215 \text{ N/mm}^2$ and $R_{p0.2} \geq 160 \text{ N/mm}^2$			
	t_{II} [mm]			
	1.80	2.00	2.50	3.00
$N_{R,II,k}$ [kN]	2.05	2.30	3.25	4.34

Component II	S235 to S355, S280GD to S450GD			
	t_{II} [mm]			
	1.20	1.50	2.00	3.00
$N_{R,II,k}$ [kN] ¹⁾	2.04	2.58	3.95	7.36

Additional definitions

Index ¹⁾: For component II made of S320GD to S450GD the resistance values may be increased by 8.3%.

Self-tapping screw	Annex 8
TDA-S-5,8xL	

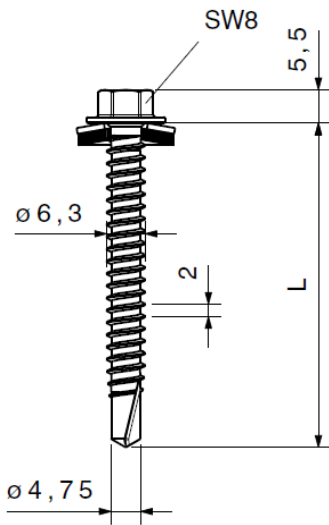

Materials:

Fastener: Stainless steel A2 or A4 - EN ISO 3506

Washer: -

Component I: -

Component II: S250GD to S450GD - EN 10346 or
S235 to S355 - EN 10025
S280GD to S450GD - EN 10346

Drilling-capacity: $\Sigma(t_{ii}) \leq 4.00$ mm

Component II	For S250GD to S450GD				
	t_{ii} [mm]				
	1.00	1.50	2.00	3.00	4.00
$N_{R,II,k}$ [kN]	1.18	1.29	1.29	1.29	1.29

Component II	for S235 to S355, S280GD to S450GD					
	t_{ii} [mm]					
	1.00	1.20	1.50	2.00	3.00	4.00
$N_{R,II,k}$ [kN]	1.54	1.80	2.48	3.88	6.95	6.95

For component II made of S320GD to S450GD the resistance values may be increased by 8.3%.

Self-drilling screw

SX5-6,3xL

Annex 9

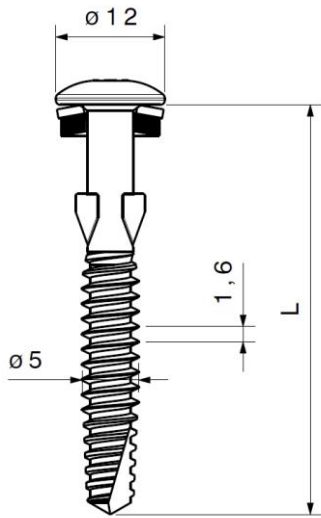

Materials:

Fastener: Stainless steel A2 or A4 - EN ISO 3506

Washer: -

Component I: -

Component II: Timber (coniferous timber) - EN 14081

Drilling-capacity: -

Characteristics: $M_{y,Rk} = -$
 $f_{ax,k} = 6.57 \text{ N/mm}^2$ ($l_{ef} = 30 \text{ mm}$, $\rho_a = 350 \text{ kg/m}^3$)

Component II	l_{ef} [mm]					
	30	35	40	45	50	55
$N_{R,II,k}$ [kN]	0.89	1.04	1.18	1.33	1.48	1.63

Additional definitions

The indicated resistance values $N_{R,II,k}$ are determined with $k_{mod} = 0.9$ and $\rho_k = 350 \text{ kg/m}^3$.

Self-drilling screw

SCFW-S-5xL

Annex 10

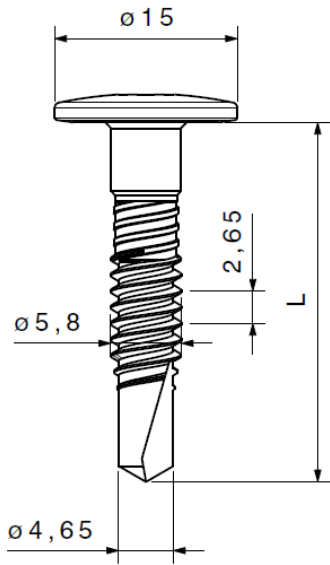

Materials:

Fastener: Stainless steel A2 or A4 - EN ISO 3506

Washer: -

Component I: -

Component II: Aluminum alloy - EN 573

Drilling-capacity: $\Sigma(t_{II}) \leq 4.00$ mm

Component II	Aluminum alloy with $R_m \geq 165$ N/mm ² and $R_{p0.2} \geq 120$ N/mm ²				
	t_{II} [mm]				
	1.80	2.00	2.50	3.00	4.00
$N_{R,II,k}$ [kN]	1.41	1.58	2.20	2.83	3.89

Component II	Aluminum alloy with $R_m \geq 215$ N/mm ² and $R_{p0.2} \geq 160$ N/mm ²				
	t_{II} [mm]				
	1.80	2.00	2.50	3.00	4.00
$N_{R,II,k}$ [kN]	1.84	2.06	2.86	3.69	5.07

Additional definitions

Self-drilling screw	Annex 11
SDA4-5,8xL	

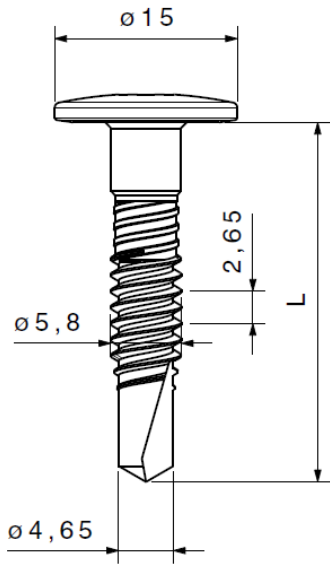

Materials:

Fastener: Stainless steel A2 or A4 - EN ISO 3506

Washer: -

Component I: -

Component II: S235 to S355 - EN 10025
S280GD to S450GD - EN 10346
Aluminum alloy - EN 573

Drilling-capacity: $\Sigma(t_{II}) \leq 4.00$ mm

Component II	Aluminum alloy with $R_m \geq 165$ N/mm ² and $R_{p0.2} \geq 120$ N/mm ²				
	t_{II} [mm]				
	1.80	2.00	2.50	3.00	4.00
$N_{R,II,k}$ [kN]	1.41	1.58	2.20	2.83	3.89

Component II	Aluminum alloy with $R_m \geq 215$ N/mm ² and $R_{p0.2} \geq 160$ N/mm ²				
	t_{II} [mm]				
	1.80	2.00	2.50	3.00	4.00
$N_{R,II,k}$ [kN]	1.84	2.06	2.86	3.69	5.07

Component II	S235 to S355, S280GD to S450GD					
	t_{II} [mm]					
	1.00	1.20	1.50	2.00	3.00	4.00
$N_{R,II,k}$ [kN]¹⁾	1.41	1.65	2.44	3.73	5.28	7.83

Additional definitions

Index ¹⁾: For component II made of S320GD to S450GD the resistance values may be increased by 8.3%.

Self-drilling screw	Annex 12
SX4-5,8xL	

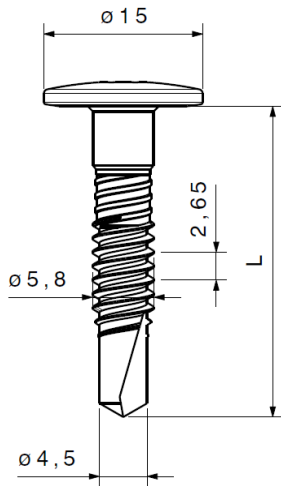

Materials:

Fastener: Stainless steel A2 or A4 - EN ISO 3506

Washer: -

Component I: -

Component II: S250GD to S450GD - EN 10346

Drilling-capacity: $\Sigma(t_{ii}) \leq 4.00$ mm

Component II	S250 GD to S450GD				
	t_{ii} [mm]				
	1.00	1.50	2.00	3.00	4.00
$N_{R,II,k}$ [kN] ¹⁾	1.13	1.23	1.23	1.23	1.23

Additional definitions

Index ¹⁾: For component II made of S320GD to S450GD the resistance values may be increased by 8.3%.

Self-drilling screw

SX4-5,8xL

Annex 13

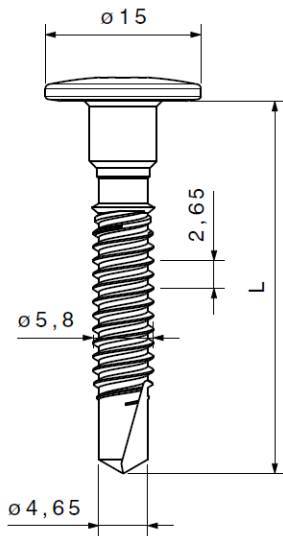

Materials:

Fastener: Stainless steel A2 or A4 - EN ISO 3506

Washer: -

Component I: -

Component II: S235 to S355 - EN 10025
S280GD to S450GD - EN 10346
Aluminum alloy - EN 573

Drilling-capacity: $\Sigma(t_{II}) \leq 4.00$ mm

Component II	Aluminum alloy with $R_m \geq 165$ N/mm ² and $R_{p0.2} \geq 120$ N/mm ²				
	t_{II} [mm]				
	1.80	2.00	2.50	3.00	4.00
$N_{R,II,k}$ [kN]	1.41	1.58	2.20	2.83	3.89

Component II	Aluminum alloy with $R_m \geq 215$ N/mm ² and $R_{p0.2} \geq 160$ N/mm ²				
	t_{II} [mm]				
	1.80	2.00	2.50	3.00	4.00
$N_{R,II,k}$ [kN]	1.84	2.06	2.86	3.69	5.07

Component II	S235 to S355, S280GD to S450GD					
	t_{II} [mm]					
	1.00	1.20	1.50	2.00	3.00	4.00
$N_{R,II,k}$ [kN]¹⁾	1.41	1.65	2.44	3.73	5.28	7.83

Additional definitions

Index ¹⁾: For component II made of S320GD to S450GD the resistance values may be increased by 8.3%.

Self-drilling screw	Annex 14
SX4-SH-5,8xL	

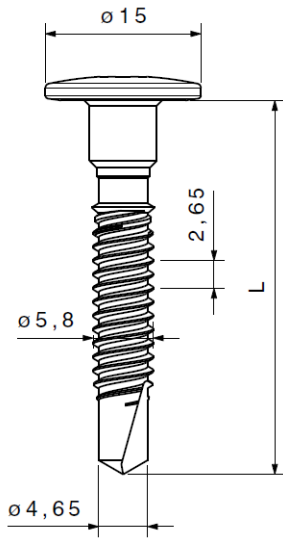

Materials:

Fastener: Stainless steel A2 or A4 - EN ISO 3506

Washer: -

Component I: -

Component II: S250GD to S450GD - EN 10346

Drilling-capacity: $\Sigma(t_{ii}) \leq 4.00$ mm

Component II	S250 GD to S450GD				
	t_{ii} [mm]				
	1.00	1.50	2.00	3.00	4.00
$N_{R,II,k}$ [kN] ¹⁾	1.13	1.23	1.23	1.23	1.23

Additional definitions

Index ¹⁾: For component II made of S320GD to S450GD the resistance values may be increased by 8.3%.

Self-drilling screw

SX4-SH-5,8xL

Annex 15

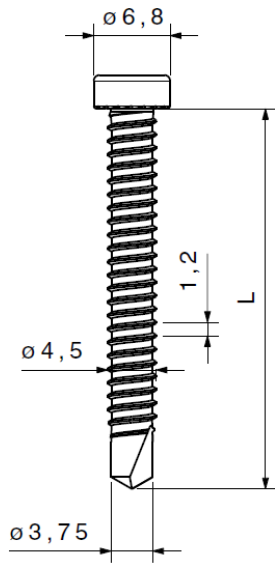

Materials:

Fastener: Stainless steel A2 or A4 - EN ISO 3506

Washer: -

Component I: -

Component II: Aluminum alloy - EN 573
Timber (coniferous timber) - EN 14081

Drilling-capacity for aluminum: $\Sigma(t_{II}) \leq 3.00$ mm

Characteristics for timber:

$f_{ax,k} = 13.45$ N/mm² ($l_{ef} = 31$ mm, $\rho_a = 350$ kg/m³)

Component II	l_{ef} [mm]
	31
$N_{R,II,k}$ [kN]	1.69

The indicated resistance value $N_{R,II,k}$ is determined with $k_{mod} = 0.9$ and $\rho_k = 350$ kg/m³.

Component II	Aluminum alloy with $R_m \geq 165$ N/mm ² and $R_{p0,2} \geq 120$ N/mm ²			
	t_{II} [mm]			
	1.80	2.00	2.50	3.00
$N_{R,II,k}$ [kN]	0.94	1.05	1.09	1.09

Component II	Aluminum alloy with $R_m \geq 215$ N/mm ² and $R_{p0,2} \geq 160$ N/mm ²			
	t_{II} [mm]			
	1.80	2.00	2.50	3.00
$N_{R,II,k}$ [kN]	1.22	1.37	1.42	1.42

Component II	Aluminum alloy with $R_m \geq 245$ N/mm ² and $R_{p0,2} \geq 200$ N/mm ²			
	t_{II} [mm]			
	1.80	2.00	2.50	3.00
$N_{R,II,k}$ [kN]	1.39	1.56	1.61	1.61

Self-drilling screw

SDAW-4,5xL

Annex 16