

SD20-5.5

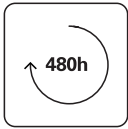
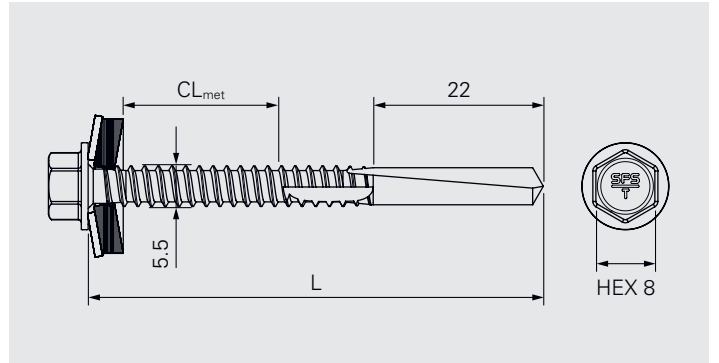

Application

Fastening of profile sheets onto metal beams

| Component 1 (t _I) | | Component 2 (t _{II}) | | $\Sigma_{\max} t_I + t_{II}$ |
|-------------------------------|-------------|--------------------------------|----------|------------------------------|
| Steel | 0.50–2.0 | Steel | 4.0–18.0 | 20.0 |
| Steel | 2×0.50–1.50 | | | 21.0 |
| Aluminium | 0.50–2.0 | | | 20.0 |

Fastener material

Carbon steel, Durocoat® 480

Sealing washer: Carbon steel galvanized, EPDM-seal

Approvals

–

Features and Benefits

- Self drilling fastener suitable for installation of profile sheets
- High quality EPDM sealing washer for long-term weather sealing
- High performance drill point for heavy steel beams
- High corrosion durability thanks to special galvanic zinc coating

Documentation

Approval document (ETA) | Declaration of performance (DoP)

All measures in mm

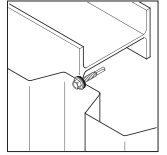

Fastener in carbon steel onto steel

| Product code | PU | L | CL _{met} | t _{fix, met} | T16 |
|-----------------|-----|----|-------------------|-----------------------|---------|
| SD20-T16-5,5×50 | 500 | 50 | 0-21 | 0-3/17 | 1673795 |

t_{fix, met}: CL_{met, min.} - (CL_{met, max.} - t_{II, max.} or load-bearing clamping length according ETA)/(CL_{met, max.} - t_{II, min.})



Accessories/Ancillaries

| Product code | PU | Drive | Head drive | |
|------------------|----|-------|------------|---------|
| SOK-IT-¼"-57-8Nm | 1 | ¼" | HEX8 | 1667322 |

All measures in mm

All information is non-binding and without guarantee. Before using the products, all specifications and calculations must be checked by a suitably qualified person and local regulations must be observed. This document is subject to revision. We reserve the right to make technical changes.