

# IG-6,0

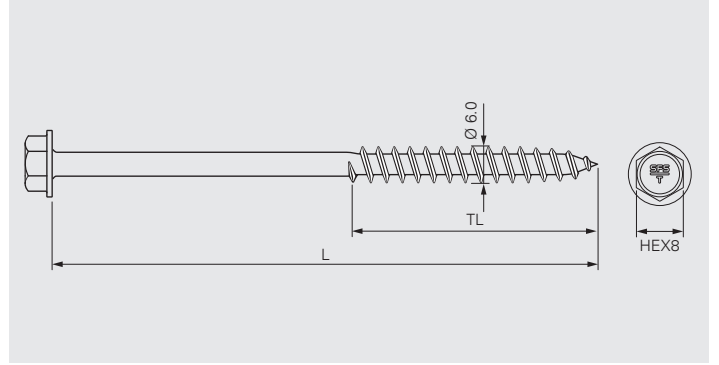

## Application

Carbon steel fastener for waterproof membrane and insulation securement on timber and timber-based boards.

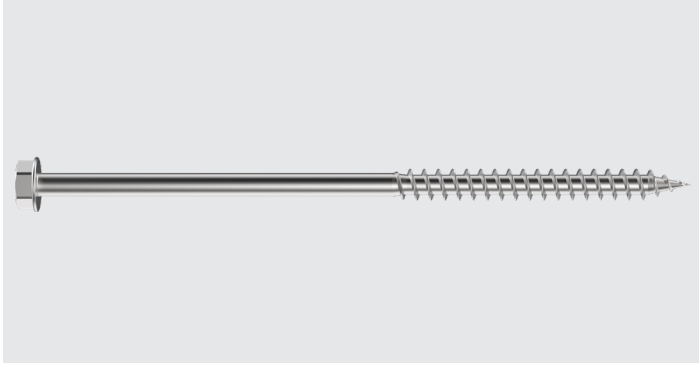
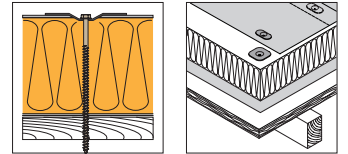

Substrate material thickness: min. 18 mm  
 Setting depth: min. 25 mm  
 Fastener length L: Clamping length CL + min. 25 mm

## Product Information

Material: Case hardened carbon steel

Corrosion protection: Durocoat®  
 Resistance 15 cycles Kesternich test according to

- EAD 030351-00-0402, A2.4
- FM Approval Standard 4470

## Approvals/Assessments

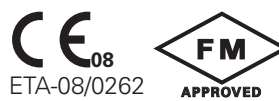

Declaration of Performance (DoP)



### Features and Benefits

- Special thread provides high pull-out values
- Fast and easy installation due to sharp tip
- High quality corrosion protection, environment friendly, free of Chromium VI

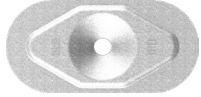

### Product Range

| Product Code | L <sub>mm</sub> | TL <sub>mm</sub> | PU  | Material No. |
|--------------|-----------------|------------------|-----|--------------|
| IG-6×80      | 80              | 55               | 500 | 22721        |
| IG-6×90      | 90              | 55               | 500 | 13170        |
| IG-6×100     | 100             | 55               | 500 | 22722        |
| IG-6×120     | 120             | 55               | 500 | 22723        |
| IG-6×140     | 140             | 55               | 250 | 22724        |
| IG-6×160     | 160             | 55               | 250 | 22725        |
| IG-6×180     | 180             | 55               | 250 | 22726        |

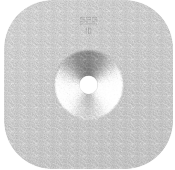
## Products to combine with

| Product Code  | Description  |   |
|---------------|--|---|
| IRD-82×40     | Stress plate for waterproof membrane and insulation securement.<br>For seam fastening application.                           |    |
| IF/IG-C-82×40 | Convex stress plate for waterproof membrane and insulation securement.<br>For seam fastening application, on hard substrate. |    |
| ID-70×70      | Stress plate for insulation securement.  |  |

## Tools and Accessories

| Product Code | Description   |   |
|--------------|---|---|
| ZA¼"         | Drive bar for socket, for manual fastener installation                |  |
| E380-3/8"-34 | Socket for fastener with HEX 8 head, for manual fastener installation |  |

## Recommendations for Installation

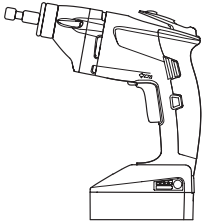
| Operating process | Recommendation   |   |
|-------------------|--|---|
| Screwing in       | Power screwdriver <ul style="list-style-type: none"> <li>• 300–700 rpm</li> <li>• Min. 500 W</li> </ul><br>Battery tool <ul style="list-style-type: none"> <li>• 300–700 rpm</li> <li>• Min. 18 V</li> <li>• Battery with min. 2,5 Ah</li> </ul> |  |