

# LBS-T25-8,0

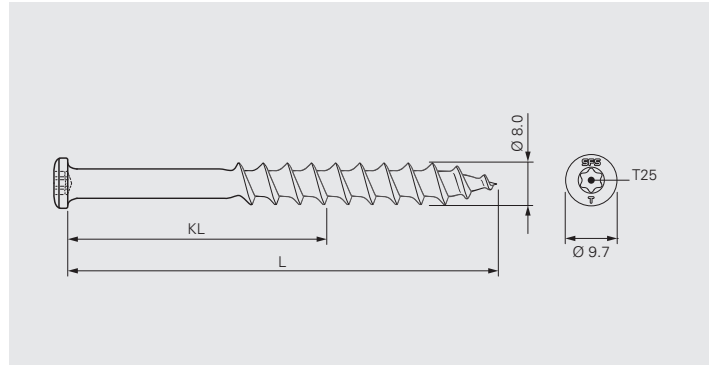

## Application

Carbon steel fastener for waterproof membrane and insulation securement on aerated concrete deck.

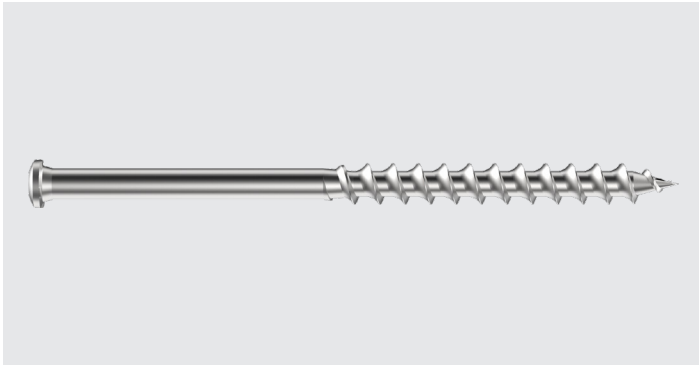
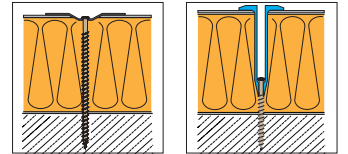

Substrate material quality: min. P3.3 (DIN 4223-1)  
 Setting depth: min. 60 mm

## Product Information

Material: Case hardened carbon steel

Corrosion protection: Durocoat®  
 Resistance 15 cycles Kesternich test according to

- EAD 030351-00-0402, A2.4
- FM Approval Standard 4470

## Approvals/Assessments



Declaration of Performance (DoP)

### Features and Benefits





---

- Fast and easy installation without pre-drilling
  - Special thread prevents overtorque and provides high pull-out values
  - High quality corrosion protection, environment friendly, free of Chromium VI
- 



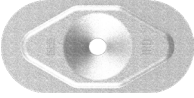
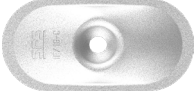

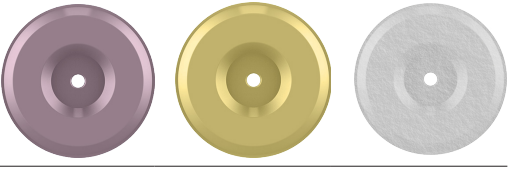

## Product Range

Product Code	L <sub>mm</sub>	TL <sub>mm</sub>	PU	Material No.
LBS-T25-8×65	65	57	500	1231834
LBS-T25-8×85	85	70	500	1231836
LBS-T25-8×105	105	70	250	1231837
LBS-T25-8×125	125	70	250	1231838
LBS-T25-8×145	145	70	250	1328069
LBS-T25-8×165	165	70	200	1328099
LBS-T25-8×185	185	70	200	1328111

## Products to combine with

Product Code	Description	
IRD-82×40	Stress plate for waterproof membrane and insulation securement. For seam fastening application.	
IF/IG-C-82×40	Convex stress plate for waterproof membrane and insulation securement. For seam fastening application, on hard substrate.	
ID-70×70	Stress plate for insulation securement.	
MW-40-LBS	Stress plate for waterproof membrane and insulation securement in combination with fasteners LBS-T25-8,0 and LBS-S-T25-8,0. For seam fastening application.	
FI-P-6,8	Stress plates for PVC, TPO and EPDM based waterproof membranes. For isoweld® field fastening application.	
RG50	Sleeve for waterproof membrane and insulation securement in combination with fasteners LBS-T25-8,0 and LBS-S-T25-8,0. For seam fastening application.	

## Tools and Accessories

Product Code	Description	
ZA¼"-M6-300 ZA¼"-M6-750	Drive bar for installation of fastener and sleeve, length 300 mm and 750 mm	
ZA¼"-M6-EXT	Drive bar extension, length 100 mm	
T25-32-M6	Insert bit with T25 drive	
ZH-11-RING	Adapter to hold sleeves R48, R50, R75 onto drive bar	
Bit holder ZA¼"	Bit holder for bits with HEX shaft	
T25-25-HEX¼"	Insert bit with T25 drive and HEX shaft	

## Recommendations for Installation

Operating process	Recommendation	
Screwing in	<p>Power screwdriver</p> <ul style="list-style-type: none"> <li>• 300–700 rpm</li> <li>• Min. 500 W</li> </ul> <p>Battery tool</p> <ul style="list-style-type: none"> <li>• 300–700 rpm</li> <li>• Min. 18 V</li> <li>• Battery with min. 2,5 Ah</li> </ul> <p>Do not use a percussion tool</p>	