

MW-40-LBS

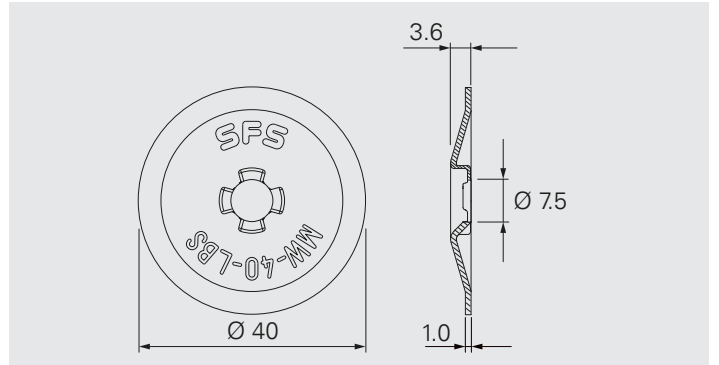

Application

Stress plate for waterproof membrane and insulation securement in combination with fasteners LBS-T25-8,0 and LBS-S-T25-8,0.
For seam fastening application.

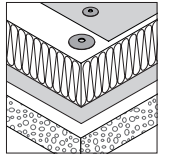

Product Information

Material:	Carbon steel, zinc plated
Corrosion protection:	Resistance 15 cycles Kesternich test according to <ul style="list-style-type: none"> EAD 030351-00-0402, A2.4 FM Approval Standard 4470

Approvals/Assessments



Declaration of Performance (DoP)

Product Range

Product Code	PU	Material No.
MW-40-LBS	500	1192327

Products to combine with

Product Code	Description	
LBS-T25-8,0	Carbon steel fastener for aerated concrete deck.	
LBS-S-T25-8,0	Stainless steel fastener for aerated concrete deck.	