

RP75

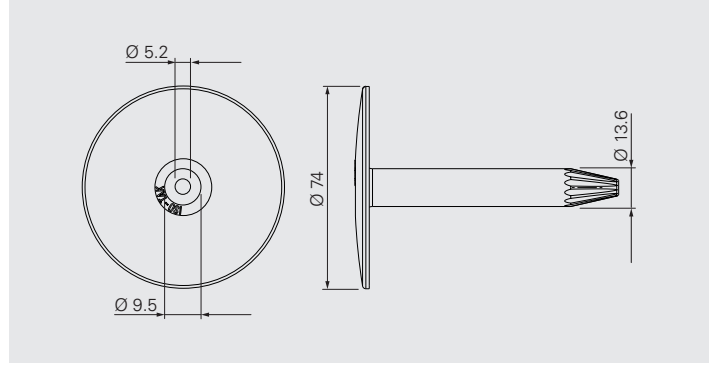

Application

Sleeve for insulation securement in combination with fasteners BS-4,8, BS3-4,8 and BS-S-4,8.

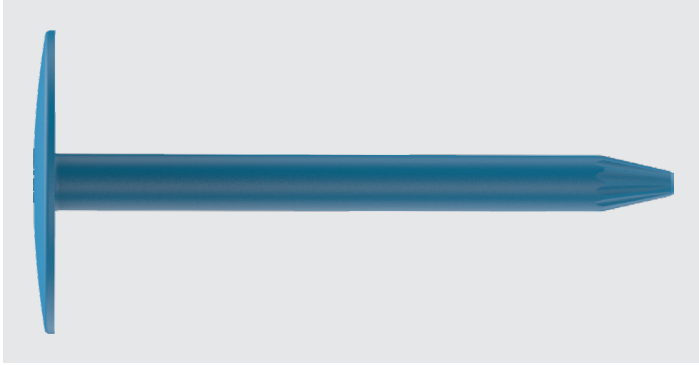
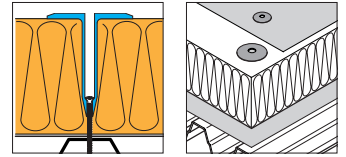

Overlap length between sleeve and fastener: 20 mm

Product Information

Material: High quality polypropylen (PP)

Approvals/Assessments

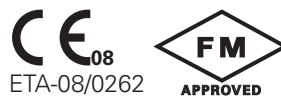

Declaration of Performance (DoP)



Features and Benefits

- Designed for insulation securement
- Optimized sleeve tip for reduced penetration force



Product Range

Product Code	L _{mm}	PU	Material No.
RP75×30	30	1000	1047235
RP75×60	60	500	1047243
RP75×90	90	500	1047245
RP75×120	120	500	1047246
RP75×150	150	500	1047247
RP75×180	180	250	1332347
RP75×210	210	250	1332349

Products to combine with

Product Code	Description	
BS-4,8	Carbon steel fastener for steel deck and timber and timber-based boards.	
BS-S-4,8	Stainless steel fastener for steel deck and timber and timber-based boards.	
BS3-4,8	Carbon steel fastener for thick steel deck.	

Tools and Accessories

Product Code	Description	
ZA¼"-M6-300 ZA¼"-M6-750	Drive bar for installation of fastener and sleeve, length 300 mm and 750 mm	
ZA¼"-M6-EXT	Drive bar extension, length 100 mm	
T25-32-M6-RING	Insert bit with T25 drive and ring to hold sleeves RP48, RP50, RP75 onto bit	